

**Product Name: ZX114ER5CS-75 Samtec Connector Saver - Breakout Adapter Rugged High Speed Strip PAM4 NRZ Edge Rate – Page 1 of 2**

**Product Description:** 40 pins x 2 rows, 80 pins Samtec Connector Saver - breakout adapter. Offering both ERM5 & ERF5 Rugged High Speed Strip PAM4 NRZ Edge Rate Samtec connectors on connector saver module with debug access point providing full feature breakout adapter for purpose of test and measurement.

- 1- Each ERF5 signal is routed to associated ERM5 connector through board to board via. Pin 1 of ERM5 is connected to pin 1 of ERF5 connector.
- 2- All signals have 0.275" ( 7mm) trace access on both top and bottom layers of the PCB.
- 3- All traces have 10mils ( 0.275mm ) width, enabling soldering of any probe wires ( 36AWG solid copper – See package includes )
- 4- All traces are 50 Ohms impedance controlled.
- 5- Four, 4, layers PCB design, inner layers are GND planes.
- 6- Accessible GND test point, The test point is connected to module GND planes.
- 7- Offering Extended height ERM5 connector ( 0.309" – 7.84mm ) , providing interface clearance from host components.
- 8- Mated ERF5-ERM5 ( Host with ZX114ER5CS-75 ) height 0.394" ( 10.00mm )
- 9- Ease of interface with single channel and differential scope probes.
- 10- User may relocate any ERM5 signal by cutting trace before the via and solder to new location or external test equipment.
- 11- Fully compatible with Single Ended , SE, and Differential Pair, DP, Samtec connector ERF5 ERM5 series as well as cable assemblies
- 12- Mates with any height and formfactor ERF5 ERM5 connector series such as ERM5, ERF5, and -RA configurations.
- 13- The module is shipped with 12pc of probing wires – See package includes, ZX00BC2PH1

**Electrical:** Insertion loss > -2dB @8GHz  
 Trace impedance: 50 Ω  
 Operating Temperature: -55°C to +125°C  
 Trace width: 10mils ( 0.254mm )  
 Trace to Trace Spacing: 10mils ( 0.254mm )  
 Trace Length: 0.275" ( 7mm )  
 Trace to Trace via: 30mils (0.8mm) from end of PCB trace  
 PCB Clearance : 0.394" ( 10.0mm ) from Host PCB ( ERF5 on host )  
 36AWG Bare copper wire : 0.042mm diameter - See package includes, ZX00BC2PH1

**Application:** Manufacturing test and re-use, bringup, testing , debugging

**Mates with :** Samtec Rugged High Speed Strip PAM4 NRZ Edge Rate ERM05 , ERF05  
 Mates with any ERM5 ERF5 cable assembly or board to board interface solution.

**Pitch:** 0.50mm (0.0197") High Speed connector

**Access:**  
 For signal measurements:  
 1- Recommendation: Use 36AWG solid copper wire with pin header,ZX00BC2PH1 or similar

For signal relocation:  
 1- Cut the trace to the connecting via ( 30 mils [ 0.8mm ] before end of trace )  
 2- Using 36AWG solid copper wire, make the required connections. See Signal Access & re-route, **Page 2**  
 ( figure "ZX114ER5CS-75 – portion of Top View " ).

ZX114ER5CS-75  
 Zebax.com

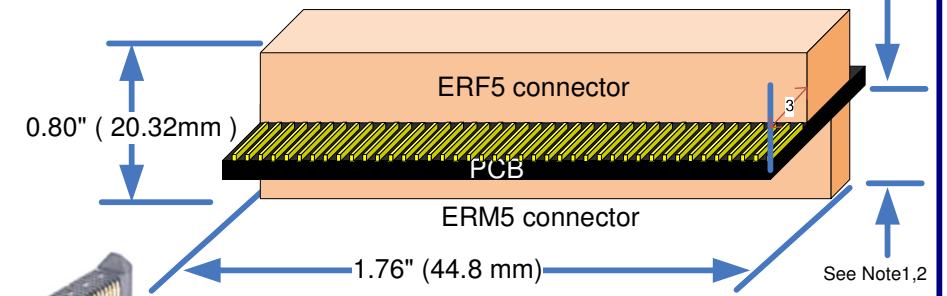
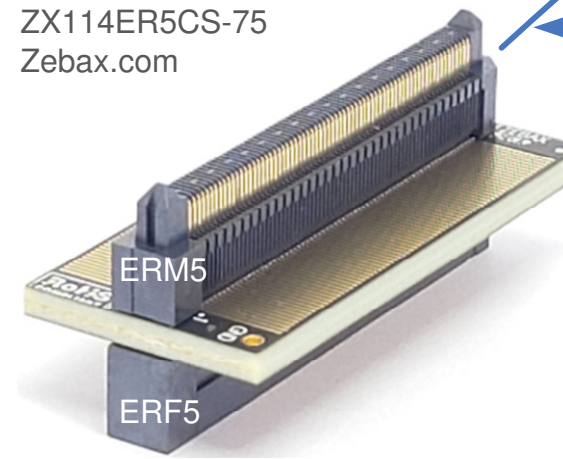

ZX114ER5CS-75 - Notes:  
 1- ERM5 height 0.309" ( 7.84mm )  
 2- Mated ERM5 – ERF5 height 0.394" ( 10.00mm )  
 3- PCB Extends 0.275" ( 7mm ) from the ERF5 connector

ZX114ER5CS-75 -Simplified Circuit Diagram

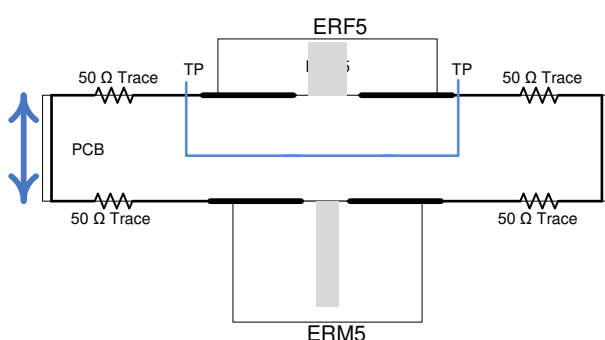

All traces are controlled 50 Ω impedance  
 The GND Test Point , has direct connection to inner PCB ground planes

ZX114ER5CS-75 Cross section view

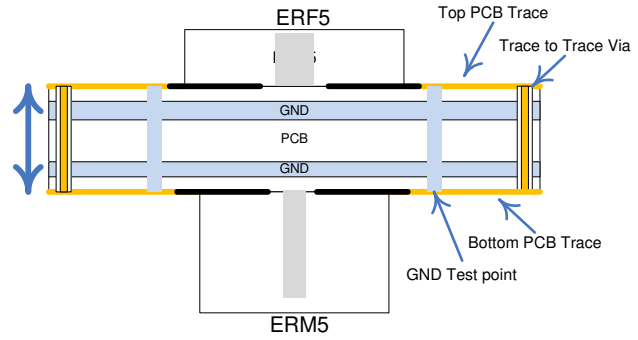

4 Layers PCB design - where 2 inner layers are Ground planes



**Compliance:**  
 ISO2001 certified  
 RoHs - Lead Free  
 EU RoHS2  
 UL E111594 document  
 ELV- Vehicle Directive ( Directive 2000/EC )  
 European Union Directive ( 203/11/EC )  
 Halogen Free per IEC-61249-2.21 : 2003  
 RoHs Directive 2011/65/EU  
 WEEE Directive ( 2012/12/EU )

Certificate of Compliance for Radioactive substances  
 Certificate of Compliance for Asbestos  
 Certificate of Compliance for Ozone Depleting Substances, ODS  
 Certificate REACH SVHC  
 Certificate of Compliance RoHS\_EN\_CoC

**ZX114ER5CS-75 package includes:**

Part number	Quantity	Description
ZX114ER5CS-75	1	Connector Saver Breakout Adapter module
ZX00BC2PH1	12	36AWG Bare Copper wire to pin header wire assembly

Note : ALL ZEBAX products are RoHS compliant and Lead Free unless otherwise indicated.

<b>ZEBAX TECHNOLOGIES</b> SANTA CRUZ, CA U.S.A (831) 222-0717 WWW.ZEBAX.COM		
SPECIFIED DIMENSIONS ARE INCHES (MM). ROHS COMPLIANT		ASSEMBLY DRAWING ITEM: ZX114ER5CS-75
DESCRIPTION: Samtec Connector Saver - Rugged High Speed Strip PAM4 NRZ Edge Rate		
CHECKED: M. MARINA	DRAWN: MATTHEW	REVISION: 1.0 SHEET: 1 OF 2

**Notice**  
 ALL ZEBAX TECHNOLOGIES DESIGN SPECIFICATIONS, DRAWINGS, PUBLICATIONS, AND OTHER DOCUMENTS (TOGETHER AND SEPARATELY, "MATERIALS") ARE BEING PROVIDED "AS IS." ZEBAX MAKES NO WARRANTIES, EXPRESSED, IMPLIED, STATUTORY, OR OTHERWISE WITH RESPECT TO THE MATERIALS, AND EXPRESSLY DISCLAIMS ALL IMPLIED WARRANTIES OF NO INFRINGEMENT, MERCHANTABILITY, AND FITNESS FOR A PARTICULAR PURPOSE.  
 Information furnished is believed to be accurate and reliable. However, Zebax Technologies assumes no responsibility for the consequences of use of such information or for any infringement of patents or other rights of third parties that may result from its use. Specifications mentioned in this publication are subject to change without notice. This publication replaces all other information previously supplied. Zebax Technologies products are not authorized as in life support devices or systems.

**Product Name: ZX114ER5CS-75 Samtec Connector Saver - Breakout Adapter Rugged High Speed Strip PAM4 NRZ Edge Rate – Page 1 of 2**

Typical ZX114ER5CS-75 interface with host

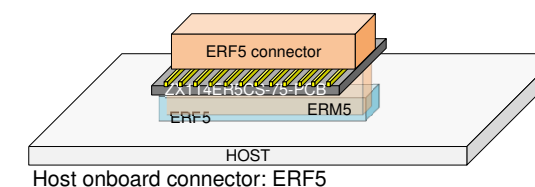

**Typical Application:** ZX114ER5CS-75 is designed for purpose of test and debugging at full connector's bandwidth. It provides new approach in usage of breakout adapters by :

- 1- Utilizing single or differential scope probe.
- 2-Enabling design changes, by re-assignment of any signal by means of cut and solder, where any signal may be cut and assigned to new location by jumper wires.

**Scope Probe wire Installation:**

- 1- It is recommended to keep the probe wire length at 0.5" ( 1.2cm ) long.
- 2- In order to avoid ground loop problems, please use the shortest Ground probe wire interfacing to the nearest GND reference. ZX114ER5CS-75 provides one GND test point to be utilized as GND reference interface with the host.
- 3- Both Keysight as well as Tektronix offer variety of single ended as well as differential probes along with their accessories, below are few probes from each vendor:
  - a) Keysight differential probe or similar N2795A, N2796A, 1168V, 1134B along with E2677B differential Solder-in probe, N5426A ZIF Tip, N2884A Fine Wire ZIF Tip and more – See the figure "probe head accessories".
  - b) Tektronix offers several single-ended as well as differential probes such as : P6245, P6248, P6247, P6246 or any of TDP7000 series and more
- 4- Please follow your vendor's guideline in installation of probe wires & accessories.

**Signal Access & re-route:**

Re-routing any signal on ZX114ER5CS-75 may be implemented by cutting the trace min. of 30 mils ( 0.8mm ) before end of the trace on top or bottom side of the PCB. The Via ( inner connecting via ) at end of the trace connects the top layer's signal ( trace ) to bottom layer's signal ( trace ). The inner connecting via may not be visible on most of Zebax designs. The via has clearance of 30mils from end of the trace.

ZX114ER5CS-75 module is 4 layers PCB where the inner layers are Ground layers. They are connected to the GND test point . For improved signal integrity, please connect the GND test point to system GND reference point. See Cross Section View figure on Page 1 for details.

**Mating and Un-mating:**

Uneven or off—angle forces during mating and un-mating of ZX114ER5CS-75 from host or daughter card may cause overstress and damage to the contacts, housing or solder joints. Severe side-to-side rocking motions should be prohibited. Un-mate ZX114ER5CS-75 by lifting one end of the connector ( peeling ) is permitted. However, this should only be done to initiate separation of the mated contacts at one end of the interfaced connector. The separation angle should be kept as low as possible as the contacts continue to un-mate, thereby spreading out the un-mating forces over the length of the interface connectors. The connectors should not be "peeled" beyond a 20° angle. See Figure below.

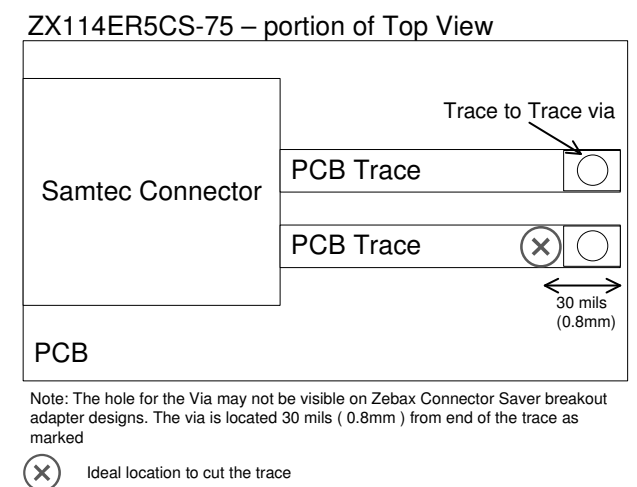
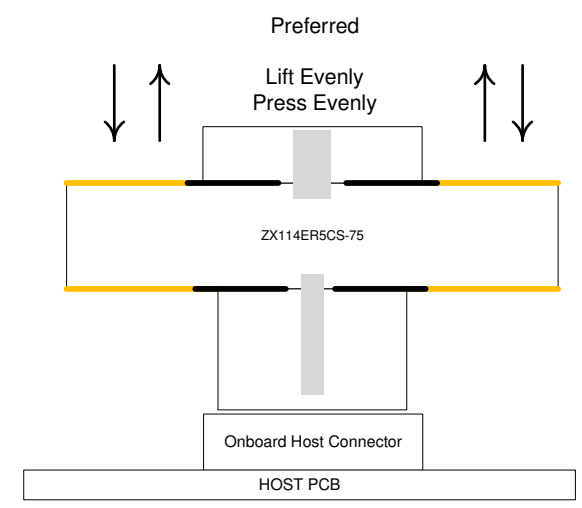

**Keysight Probe Head accessories**

<p><b>InfiniiMax RC Probe Heads</b></p> <ul style="list-style-type: none"> <li>MX0100A Diff. Micro</li> <li>MX0103A Bullet Adapter</li> <li>MX0106A Diff. Solder-In</li> <li>N2839A Diff. Browser</li> <li>MX0105A Diff. SMA</li> </ul>	<p><b>InfiniiMax II Probe Heads</b></p> <ul style="list-style-type: none"> <li>N5381B Diff. Solder-In</li> <li>N5380B SMA</li> <li>N5425B ZIF</li> </ul>	<p><b>InfiniiMax I Probe Heads</b></p> <ul style="list-style-type: none"> <li>E2677B Diff. Solder-In</li> <li>E2678B Diff. Socketed</li> <li>E2675B Diff. Browser</li> <li>N5426A ZIF Tip</li> <li>N2884A Fine Wire ZIF Tip</li> <li>N5451A Long-Wired ZIF Tip (7 mm)</li> <li>N5451A Long-Wired ZIF Tip (11 mm)</li> </ul>
---	--	---

Note : ALL ZEBAX products are RoHS compliant and Lead Free unless otherwise indicated.

<b>ZEBAX TECHNOLOGIES</b>		
SANTA CRUZ, CA U.S.A (831) 222-0717		
WWW.ZEBAX.COM		
SPECIFIED DIMENSIONS ARE INCHES (MM). ROHS COMPLIANT	<b>ASSEMBLY DRAWING</b>	
<b>ITEM: ZX114ER5CS-75</b>		
<b>DESCRIPTION: Samtec Connector Saver - breakout adapter ERM5 ERF5</b>		
<b>CHECKED:</b> M. MARINA	<b>DRAWN:</b> MATTHEW	<b>REVISION: 1.0</b> <b>SHEET: 2 OF 2</b>

**Notice**  
ALL ZEBAX TECHNOLOGIES DESIGN SPECIFICATIONS, DRAWINGS, PUBLICATIONS, AND OTHER DOCUMENTS (TOGETHER AND SEPARATELY, "MATERIALS") ARE BEING PROVIDED "AS IS." ZEBAX MAKES NO WARRANTIES, EXPRESSED, IMPLIED, STATUTORY, OR OTHERWISE WITH RESPECT TO THE MATERIALS, AND EXPRESSLY DISCLAIMS ALL IMPLIED WARRANTIES OF NO INFRINGEMENT, MERCHANTABILITY, AND FITNESS FOR A PARTICULAR PURPOSE.  
Information furnished is believed to be accurate and reliable. However, Zebax Technologies assumes no responsibility for the consequences of use of such information or for any infringement of patents or other rights of third parties that may result from its use. Specifications mentioned in this publication are subject to change without notice. This publication replaces all other information previously supplied. Zebax Technologies products are not authorized as in life support devices or systems.